

Product Description

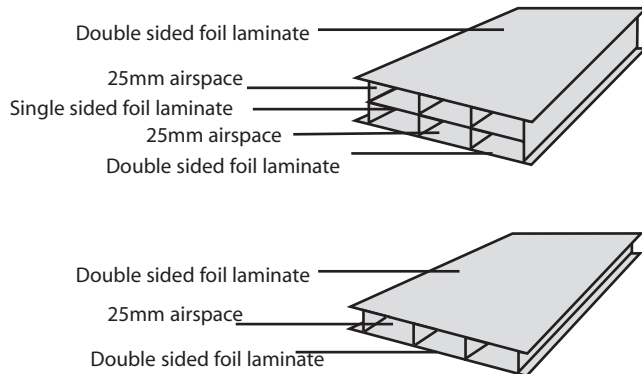

Multi-Layer Silver Batts are manufactured with layers of pure high-grade aluminium foil bonded to a substrate of Kraft paper using polymer adhesives. Two or three layers are assembled into Silver Batts, separated by a webbing of stiffened kraft. A flange at each side of the Silver Batts allows them to interlock. Silver Batts are supplied in Premium Grade and Commercial Grade. The Commercial Grade has a paper backing on one side to enable it to be glued under concrete slabs, timber floors, etc.

Finishes

Silver Batts are available in natural aluminium finish. For large orders a semi-transparent

"anti-glare" finish may be specified in any colour including flat white.

Dimensions

Triple Layer Silver Batts
450mm x 1200mm x 50mm
600mm x 1200mm x 50mm
Double Layer Silver Batts
450mm x 1200mm x 25mm
600mm x 1200mm x 25mm

Silver Batts are sold flat and expanded on site. A typical house-load fits in a car boot. A "One Square Pack", 8.64 sqm, of Triple Layer Silver Batts, weighs less than 6 kg.

Silver Batts can be manufactured to custom sizes for large orders.

Applications

Multi-Layer Silver Batts are used in ceilings, walls and floors in residential, commercial and industrial construction.

Separate application summaries are available with details of each Silver Batts system.

Health and Safety

Silver Batts are non-toxic, non-allergenic and non-irritant. No protective clothing or breathing filters are required. Not classified as hazardous according to WorkSafe Australia criteria.

Environmentally friendly

Silver Batts are made with renewable paper and aluminium, the third most abundant element in the earth's crust. As the foil layers are only 7 microns thick, the embodied energy is negligible relative to other building products.

Durability

Silver Batts are extremely durable compared with many insulation materials.

Weather

Silver Batts are generally installed from within a building. They are not designed to withstand prolonged exposure to weather and should not be stored outside.

Corrosion

In use under normal residential or commercial conditions, Silver Batts are not subject to significant degradation except in the immediate coastal vicinity, where they

can be corroded by salt. The foil coating on the Silver Batts can also be corroded if exposed to substances which are alkaline or acidic.

Dust accumulation

Silver Batts systems with horizontal surfaces that are exposed to dust accumulation are rated under the assumption that they are dust covered and reflectivity reduced to 50%. Initial performance will therefore generally be higher than stated performance.

Thermal Performance

air & aluminium

Multi-Layer Silver Batts are used in a range of systems. R values vary depending on the direction of heat flow and the thickness of reflective air spaces created. In the best case, Triple Layer Silver Batts laid over joists provide the equivalent of R6 bulk insulation between joists in summer (R2.5 in winter). Double Layer Silver Batts laid over joists provide the equivalent of R4 bulk insulation between joists in summer (R1.5 in winter). Details of insulation systems using Silver Batts are provided in Application Summaries and, for many systems, in separate Technical Bulletins.

General Comments on R values

Most R values for reflective air spaces provided in Silver Batts product literature have been calculated by Reflect 3, a computer program written by Professor Richard Aynsley, Dean of Engineering at Southern Polytechnic State University, Georgia USA, based on the algorithms of

Robinson and Powlitch. Results are consistent with the American Society of Refrigeration Heating and Air Conditioning (ASHRAE) *Fundamentals*.

The delta T used is 6 degrees Celsius in accordance with the draft Australia/New Zealand Insulation Materials Standard.

R values of common building components, including bulk insulation materials, are taken from the 3rd edition of the Technical Handbook of the Australian Institute of Refrigeration, Air Conditioning and Heating. A number of system R values have been calculated by thermal engineering consultant, James Fricker.

Important Note:

EcoCell Insulation Systems provides R value calculation only as a service to its clients. These calculations are intended solely as a general guide. The company does not represent itself as having expertise in building engineering. Readers are advised to seek professional advice in regard to the factors affecting a particular project and not to rely on the general guidance provided in our literature.

Acoustic

Calculations by accoustical consultants Graeme E Harding & Associates Pty Ltd show that the sound sound isolation against traffic

noise of a typical brick veneer home insulated with Silver Batts is equal to that of the same home insulated with fibrous insulation.

Moisture Absorption

A build-up of moisture within bulk insulation can lead to corrosion of steel building members and rotting of timber, particularly in humid areas and where buildings are continuously air conditioned for much of the year. Vapour barriers are commonly specified to eliminate this risk.

As Silver Batts do not absorb moisture there is no need for a separate vapour barrier when they are used. Research by the CSIRO has demonstrated that foil membranes in walls in climates as cold as Canberra will not condense moisture when properly installed.

Fire performance

The Building Code of Australia calls for fire performance to be tested under Australian Standard AS 1530.3, Early Fire Hazard Test. When tested under this Standard by the

Building Research Association of New Zealand, Silver Batts returned a four-zero rating, the best possible.

Electrical

Unlike bulk insulation, Silver Batts do not create a fire hazard by containing heat around wiring, electrical equipment and heating flues, etc. This means that where Silver Batts are used, standard grades of wiring can be used rather than the heavier grades required with bulk insulation - Silver Batts, like all foil insulations, are specifically

excluded from AS/NZS 3008.1, clause 3.4.3, which covers the de-rating of wiring used in conjunction with bulk insulation.

Single insulated conductors, such as switches and sockets should be treated in accordance with AS/NZS 3000, clause 5.7.3.7, eg by clipping wiring together with a cable tie. Shrouds are not required.